

P01:

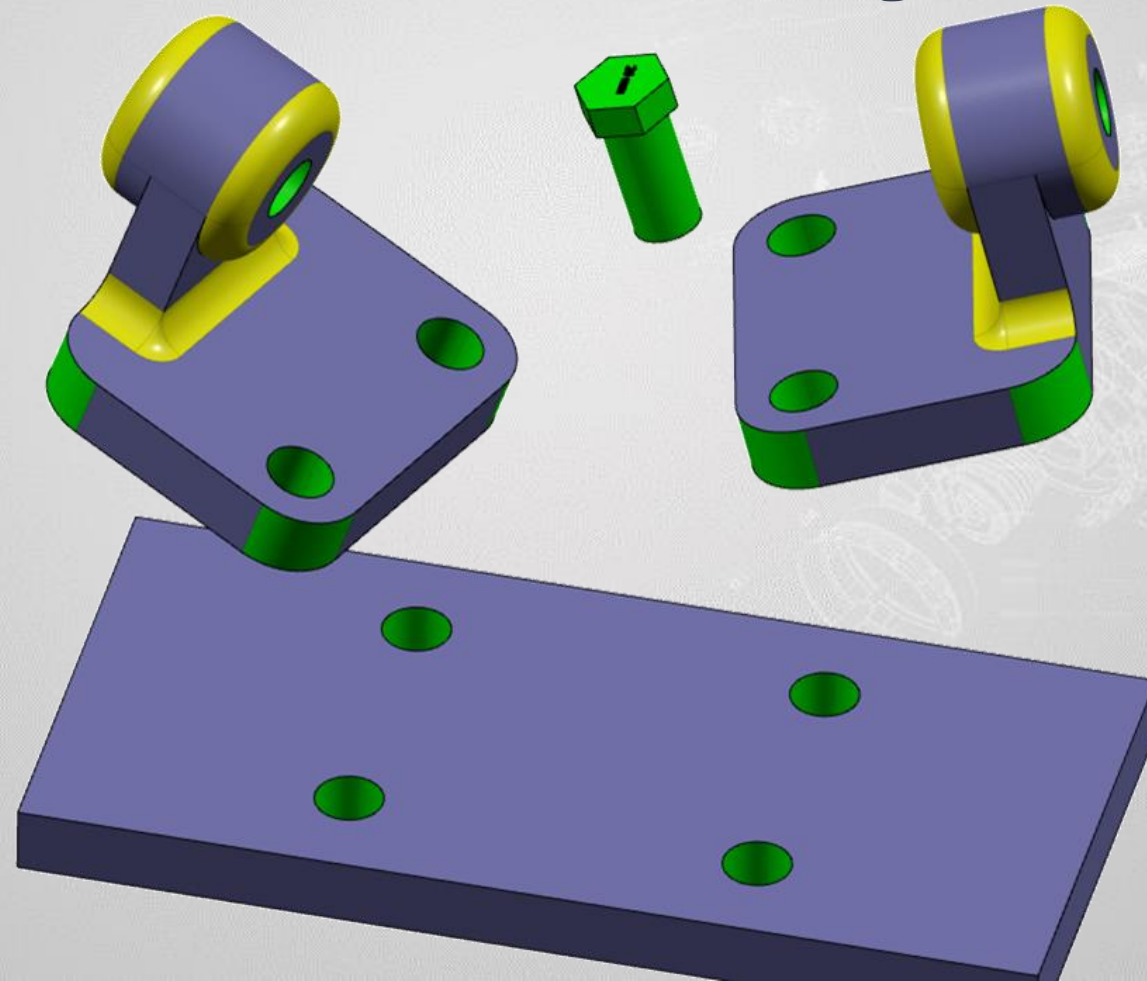

Assembly



Use your manipulation tools

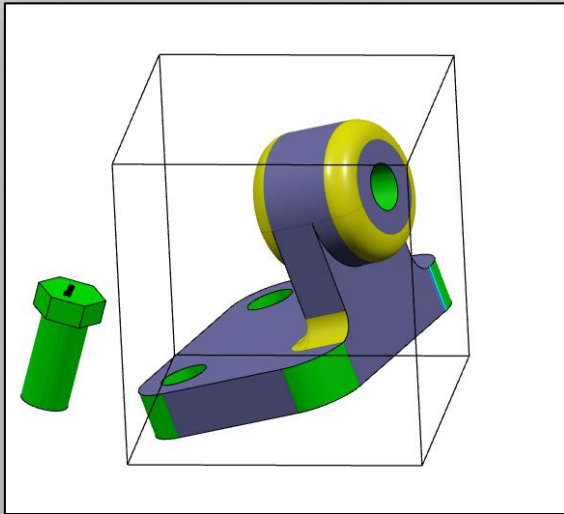

Bounding Box

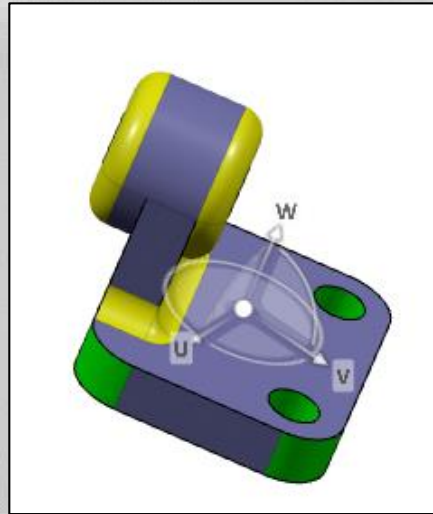

Robot

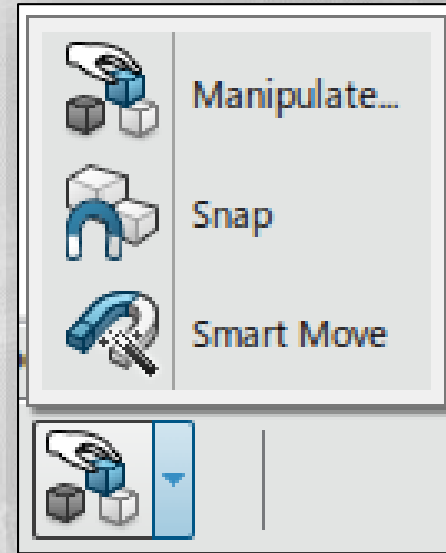

Any of these



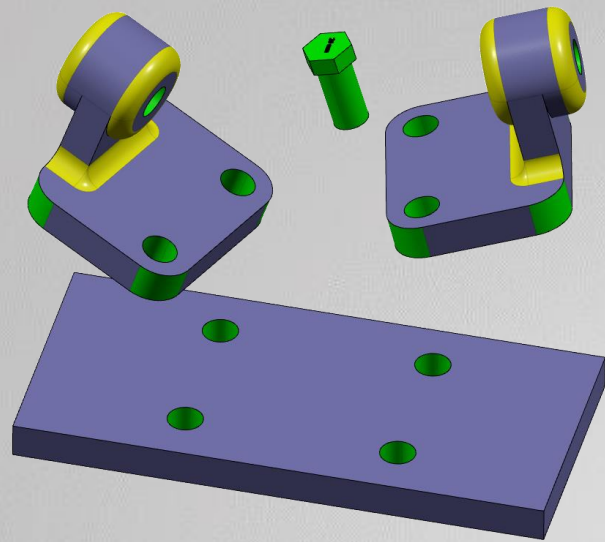

Open: P01-Assembly demo

Save w/ Options to your CS

(do NOT add your initials to the Part names)

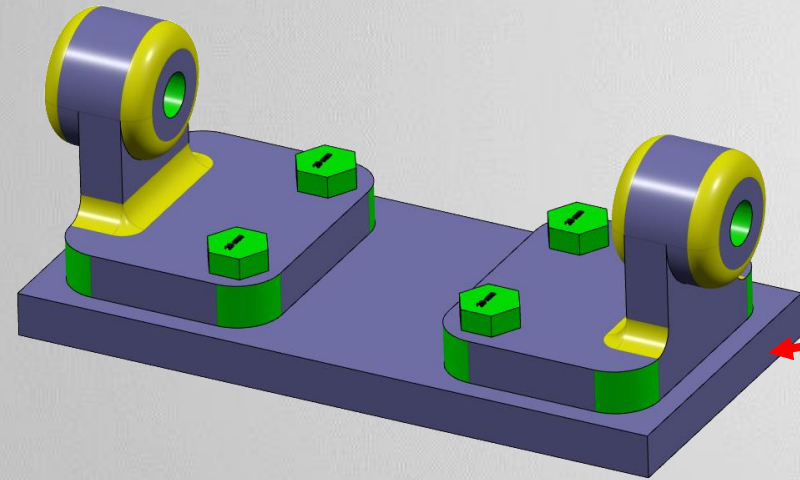

Snap it together as shown

Make sure the Base is at **Global (0,0,0)**

Save your work

You are done

